

2360 Boswell Road  
Chula Vista, CA 91914  
Phone 619.216.1444  
Fax 619.216.1474  
E-Mail tech@explorerprocomp.com



## PRO COMP SUSPENSION

---

### **Suspension Systems that Work!**

*Important: Vehicles equipped with light duty, double offset joint (rubber boot) front driveshafts must be replaced with splicer constant velocity (CV) type.*

**Part # 55591  
'92-'98 Jeep Grand  
Cherokee/Wagoneer 4WD  
3" Lift  
Now Manufactured with  
Chromolly Arms**

This document contains very important information that includes warranty information and instructions for resolving problems you may encounter. Please keep it in the vehicle as a permanent record.

## Introduction:

- ◆ **This installation requires a professional mechanic!**
- ◆ We recommend that you have access to a factory service manual for your vehicle to assist in the disassembly and reassembly of your vehicle. It contains a wealth of detailed information.
- ◆ Prior to installation, carefully inspect the vehicle's steering and driveline systems paying close attention to the tie rod ends, ball joints, wheel bearing preload, pitman and idler arm. Additionally, check steering-to-frame and suspension-to-frame attaching points for stress cracks. The overall vehicle must be in excellent working condition. Repair or replace all worn or damaged parts!
- ◆ Read the instructions carefully and study the illustrations before attempting installation! You may save yourself a lot of extra work.
- ◆ Check the parts and hardware against the parts list to assure that your kit is complete. Separating parts according to the areas where they will be used and placing the hardware with the brackets before you begin will save installation time.
- ◆ Check the special equipment list and ensure the availability of these tools.
- ◆ Secure and properly block vehicle prior to beginning installation.
- ◆ **ALWAYS** wear safety glasses when using power tools or working under the vehicle!
- ◆ Use caution when cutting is required under the vehicle. The factory undercoating is flammable. Take appropriate precautions. Have a fire extinguisher close at hand.
- ◆ Foot pound torque readings are listed on the Torque Specifications chart at the end of the instructions. These are to be used unless specifically directed otherwise. Apply thread lock retaining compound where specified.
- ◆ ***Please note that while every effort is made to ensure that the installation of your Pro Comp lift kit is a positive experience, variations in construction and assembly in the vehicle manufacturing process will virtually ensure that some parts may seem difficult to install. Additionally, the current trend in manufacturing of vehicles results in a frame that is highly flexible and may shift slightly on disassembly prior to installation. The use of pry bars and tapered punches for alignment is considered normal and usually does not indicate a faulty product. However, if you are uncertain about some aspect of the installation process, please feel free to call our tech support department at the number listed on the cover page. We do not recommend that you modify the Pro Comp parts in any way as this will void any warranty expressed or implied by the Pro Comp Suspension company.***

### PLEASE NOTE:

Due to differences in manufacturing, dimensions and inflated measurements, tire and wheel combinations should be test fit prior to installation. Tire and wheel choice is crucial in assuring proper fit performance and the safety of your Pro Comp equipped vehicle. For this application a wheel not to exceed 7" in width with a maximum backspacing of 3.5 must be used. Diameter of wheel may be any of the following 2 choices, 15" or 16". Any other diameter, either smaller or larger, will not be endorsed as acceptable by Pro Comp Suspension and will void any and all warranties, written or implied. In addition, a quality tire of radial design, not to exceed 31" tall x 10.50" wide is recommended.

Box 1-PN 55591-1

Part #	Description	Qty	Illus.
<b>91-2058</b>	<b>Front Lower Control Arm</b>	<b>2</b>	<b>3 &amp; 4</b>
<b>91-2051</b>	<b>Rear Lower Control Arm</b>	<b>2</b>	<b>6</b>
<b>90-6029</b>	<b>Brakeline Hose Support Kit:</b>		
13-20447	Hex, Self Tap 1/4" - 14 x 3/8"	4	
15-10966	Clamp, 3/8" x 3/8" x .203	4	
<b>90-6048</b>	<b>Hardware Pack Containing:</b>		
15-11252	Bushing - Red	16	3
90-2006	Sleeve .75 x .50 x 2.625	8	3
<b>90-6036</b>	<b>Hardware Pack Containing:</b>		
70-0432501500	7/16" x 2 1/2 USS Gr. 5 Hex Bolt	1	
70-0371001800	3/8" x 1" USS Gr. 8 Hex Bolt	1	
73-04300030	7/16" SAE Flat Washer	2	
73-03700034	3/8" SAE Hardened Flat Washer	2	
73-06200030	5/8" SAE Flat Washer	8	
72-04300100512	7/16" USS Nyloc Nut	1	
72-03700100816	3/8" USS Stover Nut	1	
<b>90-6375</b>	<b>Hardware Pack Containing:</b>		
91-1106	Track Bar Drop Bracket (Front)	1	5
90-2052	Spacer, 7/8" x 1.25 Lg.	1	5

**USE OF THE FOLLOWING PARTS IS MANDATORY AND MUST BE PURCHASED SEPARATELY.**

<b>55597</b>	<b>Front Sway Bar Link Kit</b>	<b>1</b>	
<b>55593</b>	<b>Coil Springs, Pair (Rear Lift)</b>	<b>1 Pair</b>	<b>2</b>
<b>324515 OR 924515</b>	<b>Front Shock Absorbers</b>	<b>2</b>	<b>2</b>
<b>324509 OR 924509</b>	<b>Rear Shock Absorbers</b>	<b>2</b>	<b>2</b>
<b>219200</b>	<b>Steering Stabilizer</b>	<b>1</b>	
<b>55592</b>	<b>Coil Springs, Pair (Front Lift)(6 cyl.)</b>	<b>1 Pair</b>	<b>2</b>
<b>or</b>			
<b>55598</b>	<b>Coil Springs, Pair (Front Lift)(8 cyl.)</b>	<b>1 Pair</b>	<b>2</b>

## Installation Instructions:

### DISASSEMBLY:

- 1) Raise and suitably support the vehicle with jackstands. Support the axle with a floor jack. Remove the wheels and tires.
- 2) Mark and disconnect the front prop shaft at the axle as shown in ILLUSTRATION 1.
- 3) Disconnect the stock lower control arm at the axle and the rear bracket and remove. Refer to ILLUSTRATION 2.
- 4) Disconnect the stabilizer bar links and the shock absorbers at the axle as shown in ILLUSTRATION 2. Remove upper shock hardware and remove shock.
- 5) Disconnect the track bar at the axle bracket.
- 6) Disconnect the drag link at the pitman arm.
- 7) Lower the axle assembly, loosen the spring retainers and remove the front springs.

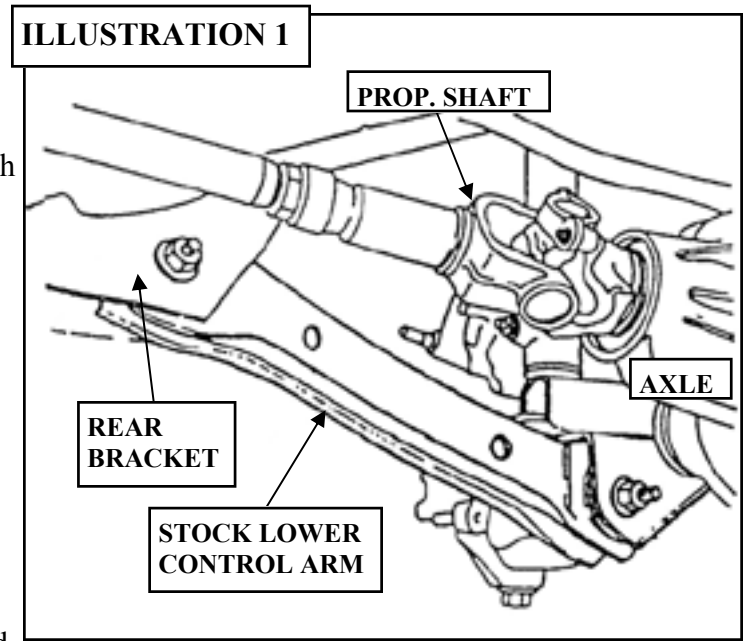

**ILLUSTRATION 2**

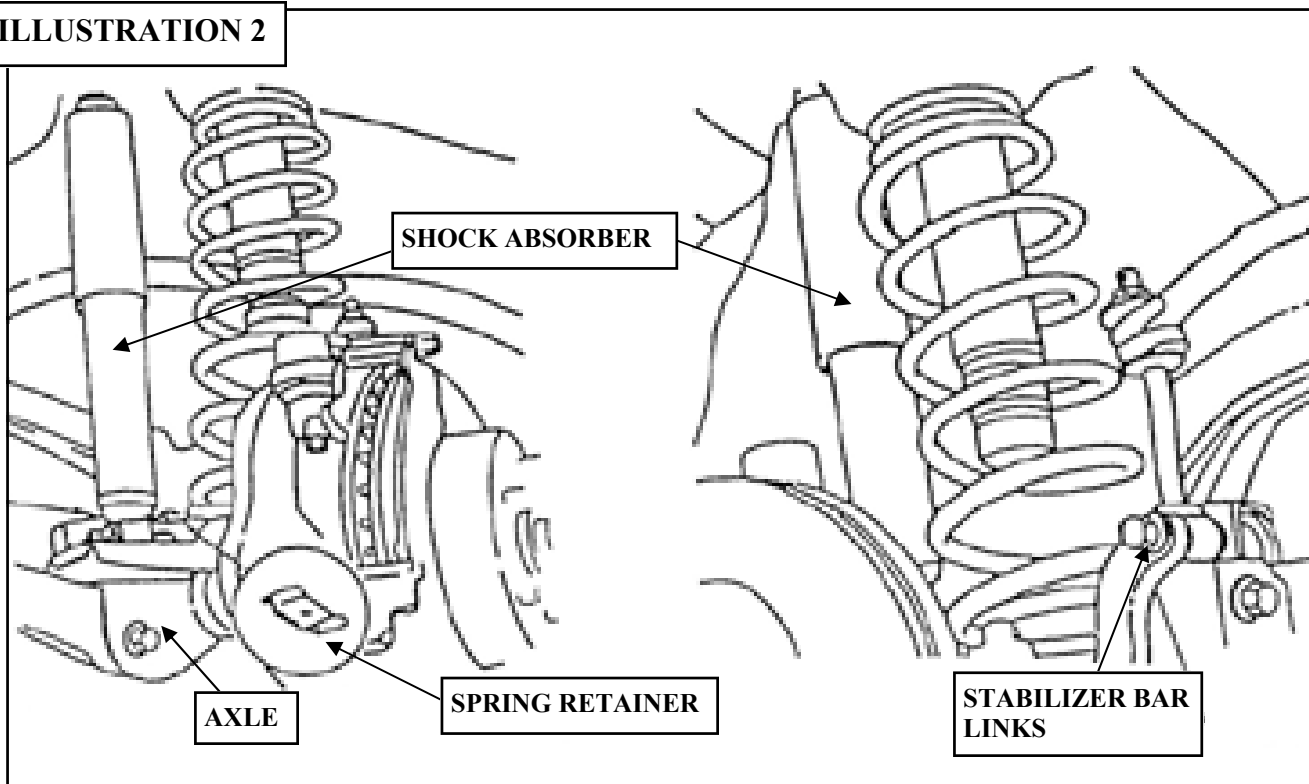

## INSTALLATION:

- 1) Install the new front springs (55592) and tighten the retainers.
- 2) Raise the axle into position.
- 3) Insert the bushings and sleeves, with grease, into the new front lower control arms (91-2058) as shown in ILLUSTRATION 3.

**NOTE: Front lower control arm (91-2058) is 16" center to center the rear lower control arm (91-2051) is 16 3/4" center to center. See ILLUSTRATION 6.**

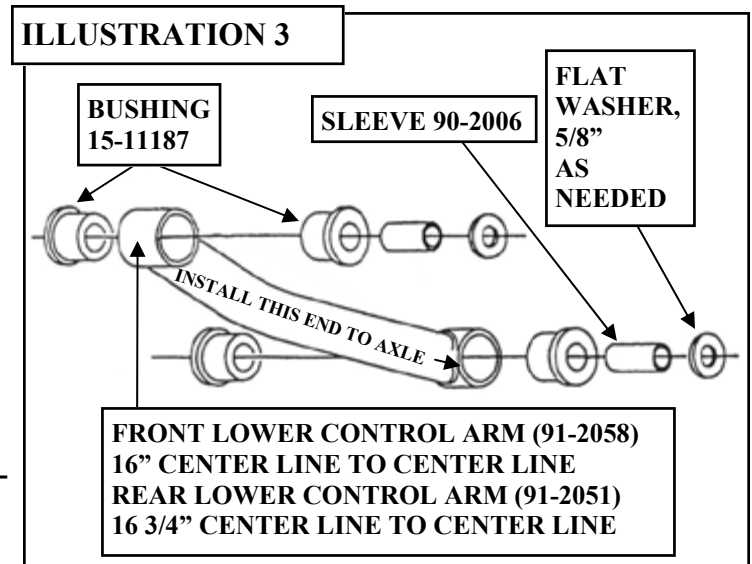

- 4) Position the lower control arms in the front and rear brackets and install using the existing bolts and nuts and the supplied washers if needed. See ILLUSTRATION 3 and 4.
- 5) Tighten the mounting bolts with a torque of 180 Nm (133 ft./lbs.)
- 6) Position the track bar drop bracket, (#91-1106) as shown in ILLUSTRATION 5. Mark the hole location on the axle bracket and drill 3/8" hole. Connect the track bar drop bracket to the axle bracket and the stabilizer bar links and shock absorbers (324515) and tighten to the axle. Refer back to ILLUSTRATION 2 if necessary. Replace upper shock hardware.
- 7) Connect the front drive shaft to the axle. See ILLUSTRATION 4.
- 8) Cycle steering lock to lock and inspect steering, suspension and driveline systems to proper operation, tightness and adequate clearance. Recheck brake hose/fittings for leaks. Be sure all hoses are long enough. Brake line hose support kit, (90-6029), is included with this kit. Use as needed.

- 9) Install the wheels and tires. Remove the jackstands and lower the vehicle.

## REAR INSTALLATION:

⇒ **Refer to ILLUSTRATION 6 for proper location of control arms.**

- 1) Raise rear of vehicle with a floor jack and support with jackstands forward of the lower rear control arm frame mounts.

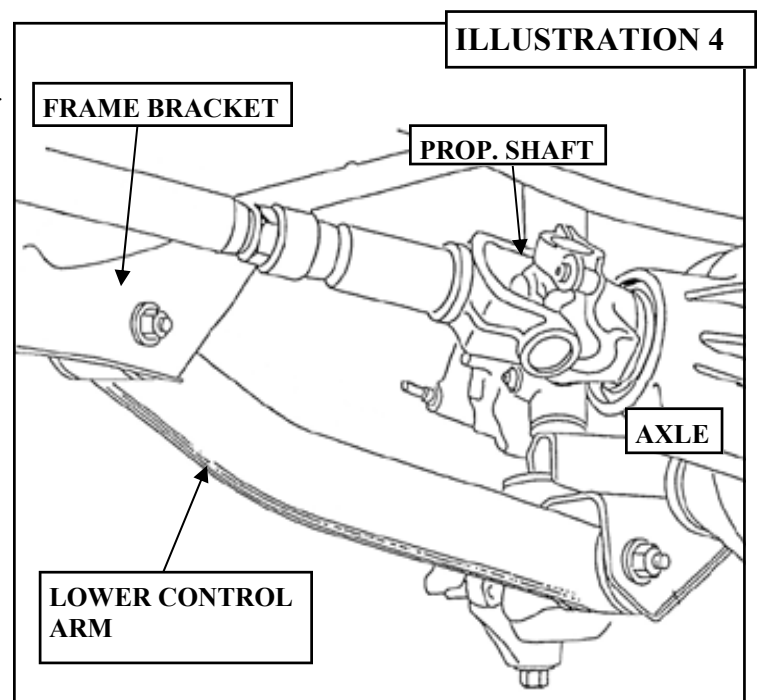

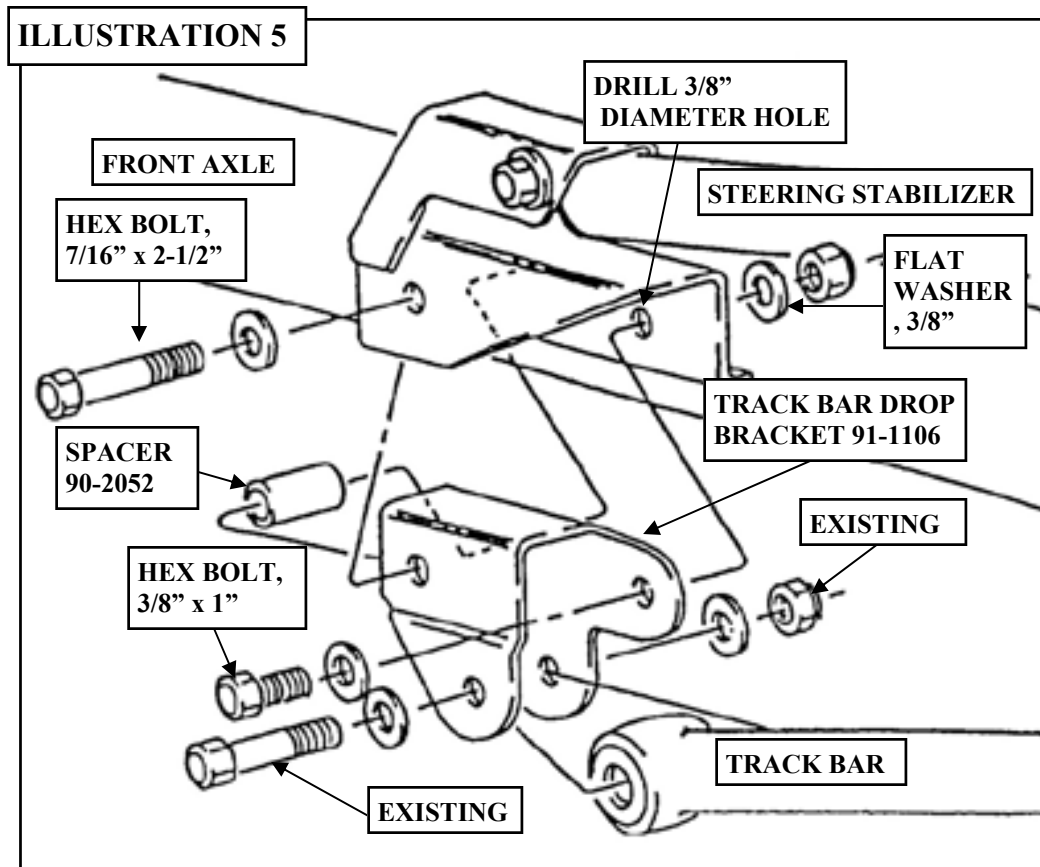

- 2) While supporting rear axle with floor jack. Remove rear shocks.
- 3) Lower rear axle to free rear coils. Be careful not to over extend brake lines or differential vent hose.
- 4) Assemble rear lower control arms (91-2051) the rear arm is 16.750" center to center measurement. Refer back to ILLUSTRATION 3.
- 5) Remove stock lower rear arm on drivers side and replace with (91-2051). Repeat on passenger side. Torque mounting bolts to 133 ft./lbs.

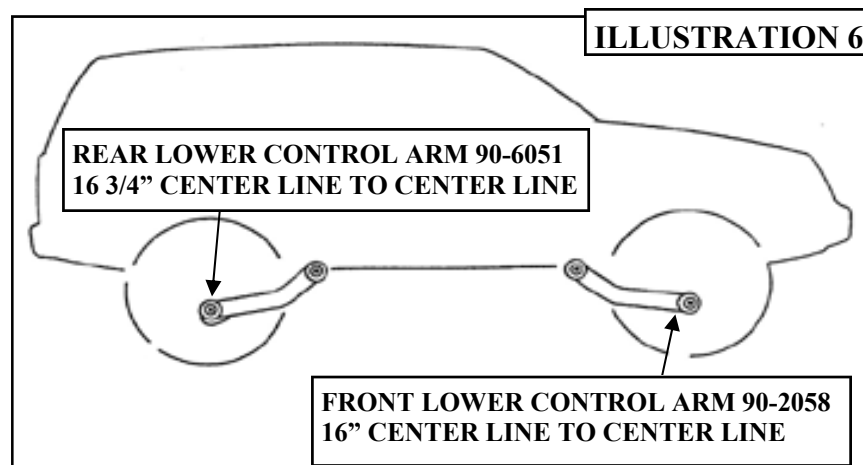

- 6) Raise axle and remove axle track bar bolt.
- 7) Lower axle enough to install rear coils. **(55593)**.
- 8) Raise axle enough to install rear shocks. **(324509 or 924509)**.
- 9) Install tires and set rear of vehicle on ground.
- 10) Replace axle track bar bolt and tighten.

### **TORQUE SPECIFICATIONS:**

<b>Lower Control Arms-to-Axle.....</b>	<b>133 ft./lbs.</b>
<b>Front Shock Absorbers at Axle.....</b>	<b>14 ft./lbs.</b>
<b>Stabilizer Bar Links-to-Axle.....</b>	<b>70 ft./lbs.</b>
<b>U-Joint Straps at Front Axle.....</b>	<b>14 ft./lbs.</b>
<b>Center Link-to-Pitman Arms.....</b>	<b>35 ft./lbs.</b>
<b>Track Bar-to-Frame Rail Bracket.....</b>	<b>35 ft./lbs.</b>

### **CASTER:**

**Caster should be checked using wheel alignment equipment. If caster is incorrect, adjustment can be made by adding or removing shims at rear of the lower control arms.**

### **FRONT WHEEL ALIGNMENT:**

**The alignment should be checked and adjusted. To ensure correct alignment, the following inspection is recommended:**

	<u><b>SET TO</b></u>	<u><b>OK RANGE</b></u>
<b>Toe:</b>		
<b>Right Wheel</b>	<b>0</b>	<b>1/32" IN to 1/32"</b>
<b>Left Wheel</b>	<b>0</b>	<b>1/32" IN to 1/32"</b>
<b>Camber</b>	<b>0</b>	<b>-1/2* to +1/2*</b>
<b>Caster</b>	<b>7-1/2*</b>	<b>7* to 8*</b>
<b>*Turn Angle:</b>		
<b>(Outside Wheel)</b>	<b>33* MAX.</b>	<b>33* to 32*</b>

⇒ **This angle may be reduced as to allow 0.5 inches minimum.**

⇒ **Maximum tire size: 31 x 10.50**

⇒ **Have head lights adjusted.**





Use this only as a guide for hardware without a called out torque specification in the instruction manual.

<b>Bolt Torque and ID</b>						
<b>Decimal System</b>			<b>Metric System</b>			
All Torques in Ft. Lbs. Maximums						
Bolt Size	Grade 5	Grade 8	Bolt Size	Class 9.8	Class 10.9	Class 12.9
5/16	15	20	M6	5	9	12
3/8	30	45	M8	18	23	27
7/16	45	60	M10	32	45	50
1/2	65	90	M12	55	75	90
9/16	95	130	M14	85	120	145
5/8	135	175	M16	130	165	210
3/4	185	280	M18	170	240	290

1/2-13x1.75 HHCS      **Grade 5    Grade 8**  
(No. of Marks + 2)

D    T    L    X

G = Grade (Bolt Strength)  
D = Nominal Diameter (Inches)  
T = Thread Count (Threads per Inch)  
L = Length (Inches)  
X = Description (Hex Head Cap Screw)

M12-1.25x50 HHCS

D    T    L    X

P = Property Class (Bolt Strength)  
D = Nominal Diameter (Millimeters)  
T = Thread Pitch (Thread Width, mm)  
L = Length (Millimeters)  
X = Description (Hex Head Cap Screw)

### **Notice to Owner operator, Dealer and Installer:**

Vehicles that have been enhanced for off-road performance often have unique handling characteristics due to the higher center of gravity and larger tires. This vehicle may handle, react and stop differently than many passenger cars or unmodified vehicles, both on and off-road. You must drive your vehicle safely! Extreme care should always be taken to prevent vehicle rollover or loss of control, which can result in serious injury or even death. Always avoid sudden sharp turns or abrupt maneuvers and allow more time and distance for braking! Pro Comp reminds you to fasten your seat belts at all times and reduce speed! We will gladly answer any questions concerning the design, function, maintenance and correct use of our products.

### **Please make sure your Dealer/Installer explains and delivers all warning notices, warranty forms and instruction sheets included with Pro Comp product.**

Application listings in this catalog have been carefully fit checked for each model and year denoted. However, Pro Comp reserves the right to update as necessary, without notice, and will not be held responsible for misprints, changes or variations made by vehicle manufacturers. Please call when in question regarding new model year, vehicles not listed by specific body or chassis styles or vehicles not originally distributed in the USA.

**Please note that certain mechanical aspects of any suspension lift product may accelerate ordinary wear of original equipment components.** Further, installation of certain Pro Comp products may void the vehicle's factory warranty as it pertains to certain covered parts; it is the consumer's responsibility to check with their local dealer for warranty coverage before installation of the lift.

### **Warranty and Return policy:**

Pro Comp warrants its full line of products to be free from defects in workmanship and materials. Pro Comp's obligation under this warranty is limited to repair or replacement, at Pro Comp's option, of the defective product. Any and all costs of removal, installation, freight or incidental or consequential damages are expressly excluded from this warranty. Pro Comp is not responsible for damages and / or warranty of other vehicle parts related or non-related to the installation of Pro Comp product. A consumer who makes the decision to modify his vehicle with aftermarket components of any kind will assume all risk and responsibility for potential damages incurred as a result of their chosen modifications. Warranty coverage does not include consumer opinions regarding ride comfort, fitment and design. Warranty claims can be made directly with Pro Comp or at any factory authorized Pro Comp dealer.

**IMPORTANT!** To validate the warranty on this purchase please be sure to mail in the warranty card.

### **Claims not covered under warranty-**

- Parts subject to normal wear, this includes bushings, bump stops, ball joints, tie rod ends and heim joints
  - Discontinued products at Pro Comp's discretion
- Bent or dented product
- Finish after 90 days
- Leaf or coil springs used without proper bump stops
- Light bulbs
- Products with evident damage caused by abrasion or contact with other items
- Damage caused as a result of not following recommendations or requirements called out in the installation manuals
- Products used in applications other than listed in Pro Comp's catalog
- Components or accessories used in conjunction with other manufacturer's systems
- Tire & Wheel Warranty as per Pro Competition Tire Company policy
- Warranty claims without "Proof of Purchase"
- Pro Comp Pro Runner coil over shocks are considered a serviceable shock with a one-year warranty against leakage only. Rebuild service and replacement parts will be available and sold separately by Pro Comp. Contact Pro Comp for specific service charges.
- Pro Comp accepts no responsibility for any altered product, improper installation, lack of or improper maintenance, or improper use of our products.

**E-Mail: [tech@explorerprocomp.com](mailto:tech@explorerprocomp.com)**  
**Website: [www.explorerprocomp.com](http://www.explorerprocomp.com)**  
**Fax: (619) 216-1474**  
**Ph: (619) 216-1444**

<b>PLACE</b>
<b><u>WARRANTY REGISTRATION</u></b>
<b><u>NUMBER</u></b>
<b>HERE: _____</b>